

SIZE

FD 4 800-900 D47

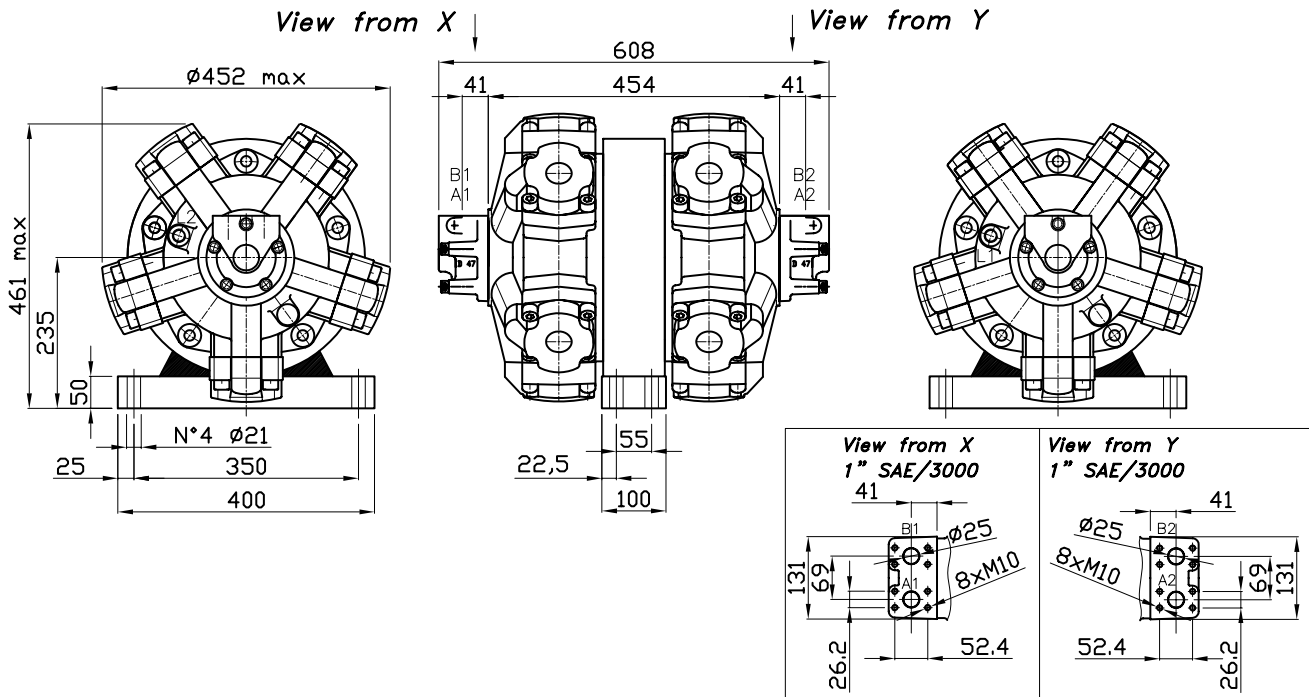

TECHNICAL DATA

FD 4 800-900 D47

MODEL	Flow per section		Displacement per section cc/Rev	Working pressure			Power per section kW
	l/min (cont)	l/min (max)		continuous bar	intermittent bar	maximum bar	
FD 4 800	250	295	792	250	280	350	88
FD 4 900	285	335	904	250	280	350	100

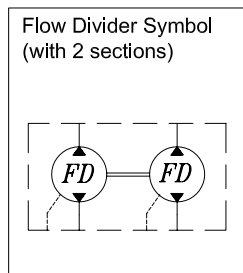

PORTS DIMENSION	
L1/L2	1/2" BSP

Dry weight 230 kg

Max case pressure 20 bar

SIZE

FD 4 800-900 D47 VB

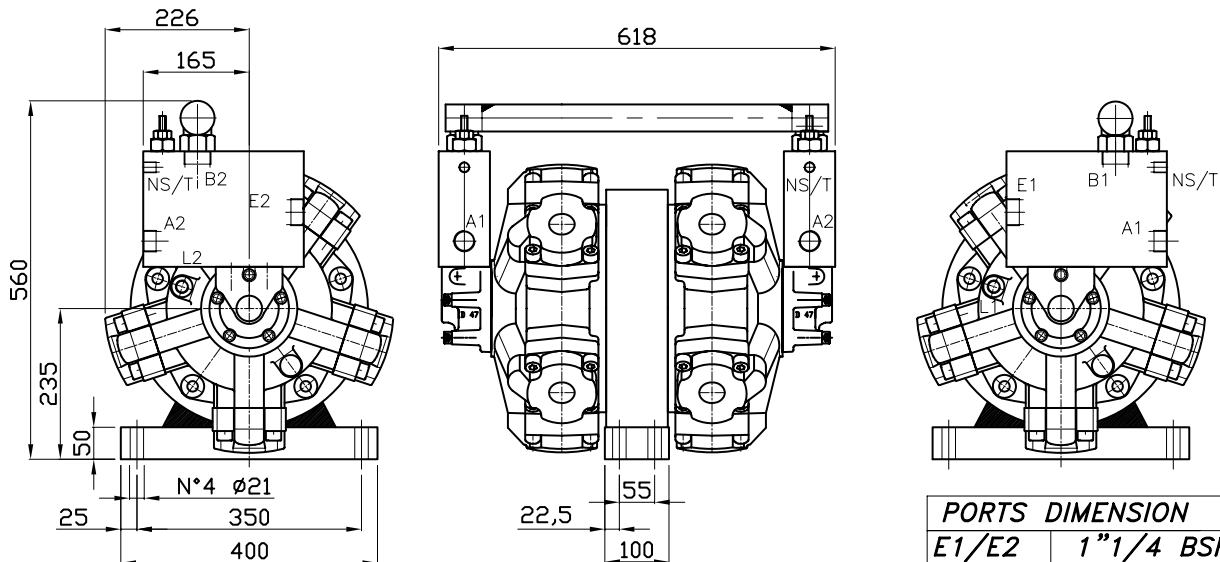

Max case pressure 6 bar

PORTS DIMENSION	
E1/E2	1"1/4 BSP
A1/A2	1" BSP
NS/T	3/8" BSP
L1/L2	1/2" BSP

TECHNICAL DATA

FD 4 800-900 D47 VB

MODEL	Flow per section		Displacement per section cc/Rev	Working pressure			Power per section kW
	l/min (cont)	l/min (max)		continuous bar	intermittent bar	maximum bar	
FD 4 800	250	295	792	250	280	350	88
FD 4 900	285	335	904	250	280	350	100

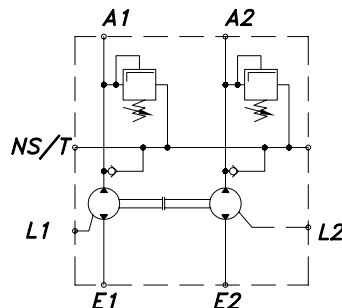
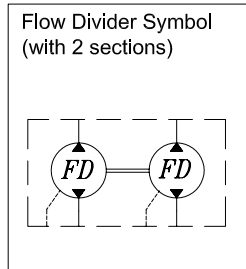

RELIEF VALVE DATA	
Rated flow	40 l/min
Adjustable pressure range	5-50 bar
	30-100 bar
	50-220 bar
	80-350 bar

Dry weight 230 kg

Max case pressure 20 bar