

SIZE

FD 2 250-350 D47

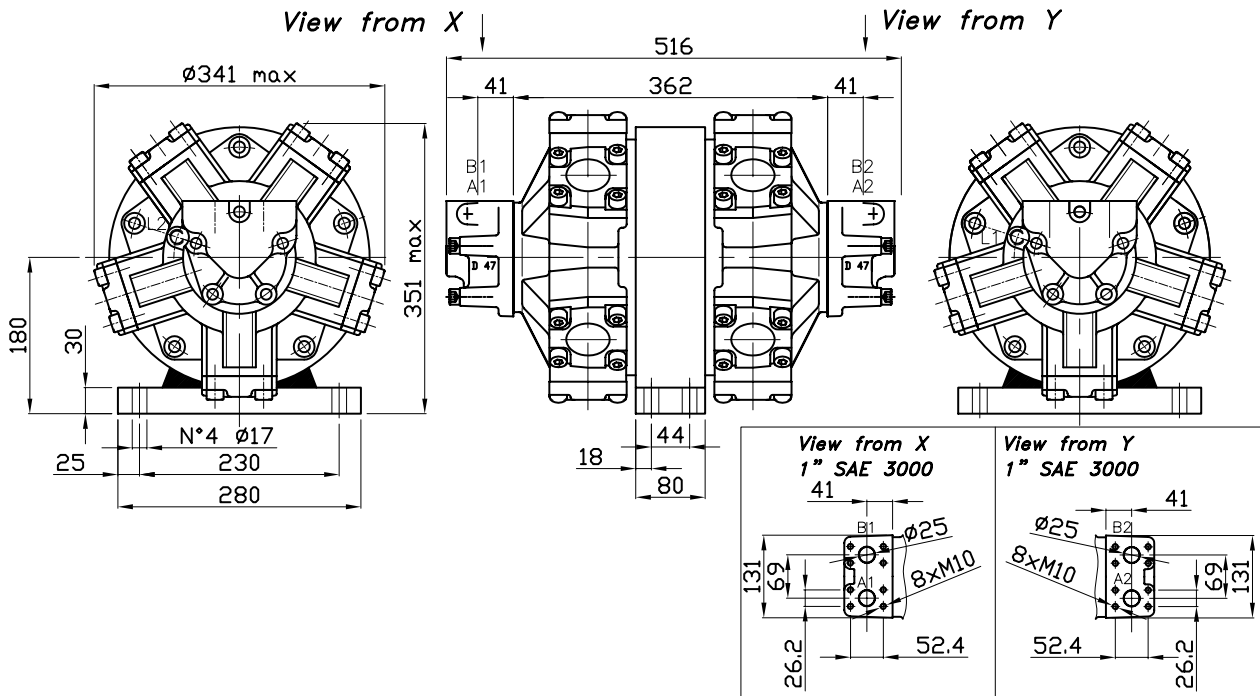

TECHNICAL DATA

FD 2 250-350 D47

MODEL	Flow per section		Displacement per section cc/Rev	Working pressure			Power per section kW
	l/min (cont)	l/min (max)		continuous bar	intermittent bar	maximum bar	
FD 2 250	130	150	253	250	280	350	45
FD 2 350	165	190	362	250	280	350	58

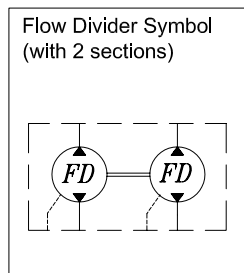

PORTS DIMENSION	
L1/L2	3/8" BSP

Dry weight 110 kg

Max case pressure 20 bar

SIZE

FD 2 250-350 D47 VB

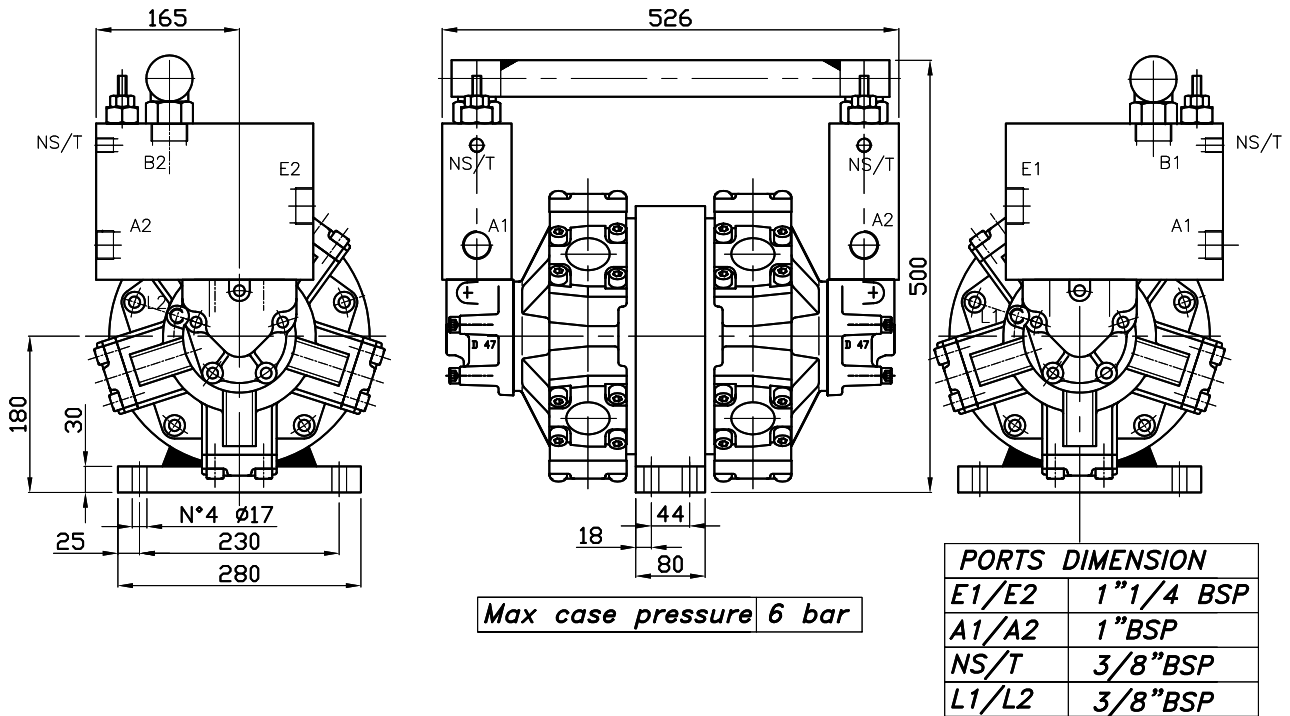

TECHNICAL DATA

FD 2 250-350 D47 VB

MODEL	Flow per section		Displacement per section cc/Rev	Working pressure			Power per section kW
	l/min (cont)	l/min (max)		continuous bar	intermittent bar	maximum bar	
FD 2 250	130	150	253	250	280	350	45
FD 2 350	165	190	362	250	280	350	58

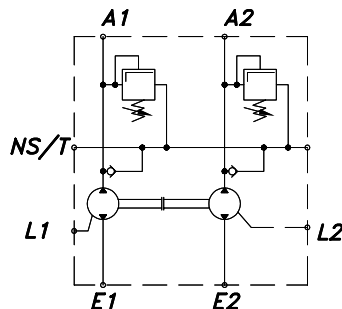
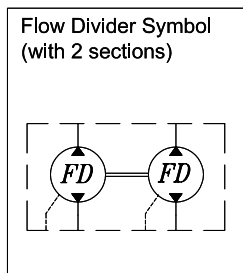

Rated flow	40 l/min
Adjustable pressure range	5-50 bar
	30-100 bar
	50-220 bar
	80-350 bar

Dry weight 110 kg

Max case pressure 20 bar