

SIZE

FD 1 80-100-150 D47

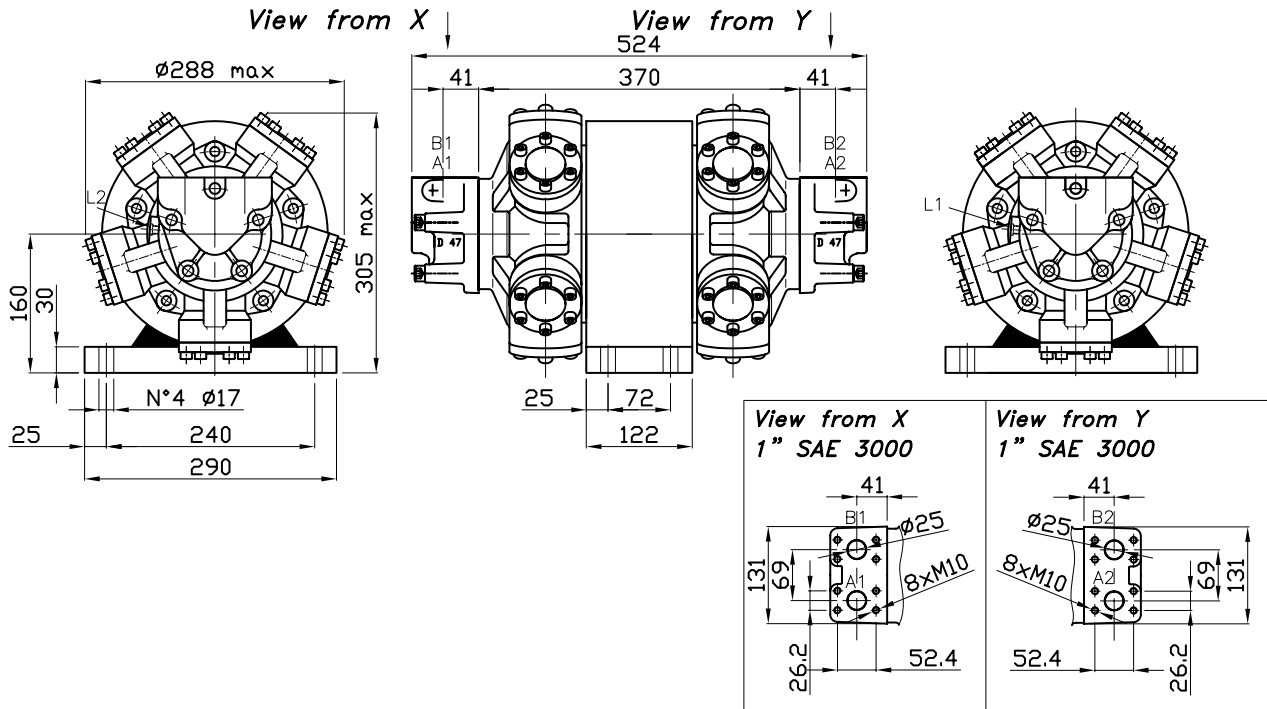

TECHNICAL DATA

FD 1 80-100-150 D47

MODEL	Flow per section		Displacement per section cc/Rev	Working pressure			Power per section kW
	l/min (cont)	l/min (max)		continuous bar	intermittent bar	maximum bar	
FD 1 80	55	65	80	250	280	350	20
FD 1 100	70	85	100	250	280	350	25
FD 1 150	110	130	157	250	280	350	38

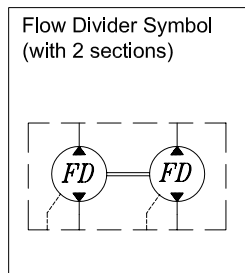

PORTS DIMENSION	
L1/L2	3/8" BSP

Dry weight 90 kg

Max case pressure 20 bar

SIZE

FD 1 80-100-150 D47 VB

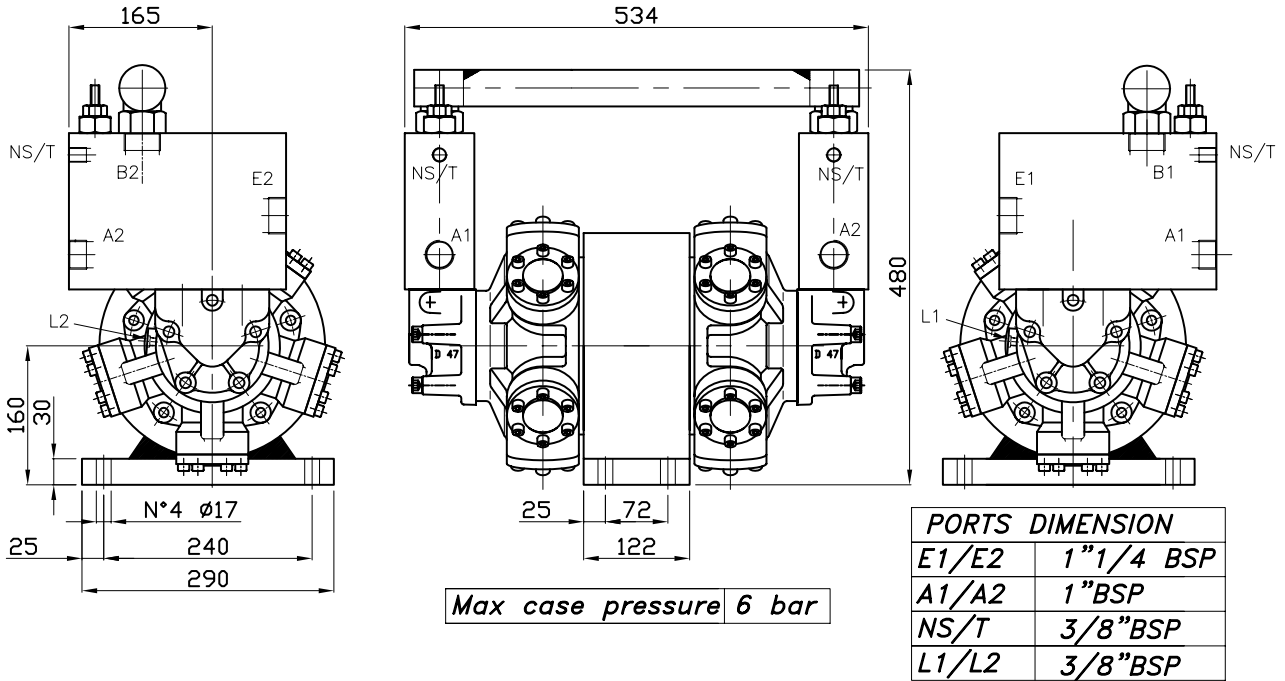

TECHNICAL DATA

FD 1 80-100-150 D47 VB

MODEL	Flow per section		Displacement per section cc/Rev	Working pressure			Power per section kW
	l/min (cont)	l/min (max)		continuous bar	intermittent bar	maximum bar	
FD 1 80	55	65	80	250	280	350	20
FD 1 100	70	85	100	250	280	350	25
FD 1 150	110	130	157	250	280	350	38

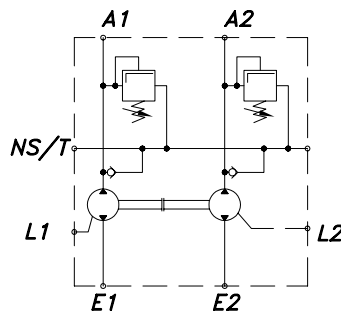
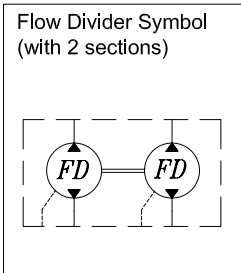

Rated flow	40 l/min
Adjustable pressure range	5-50 bar 30-100 bar 50-220 bar 80-350 bar

Dry weight 90 kg

Max case pressure 20 bar